

BM-916A

BM-917A

Chain Stitch Button Sewer

Chain Stitch Button Sewer with Thread Trimmer

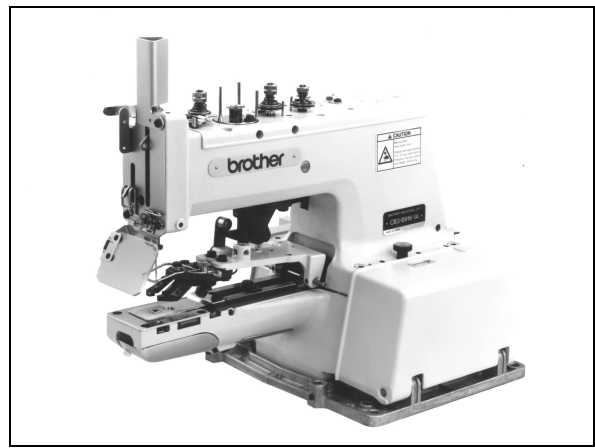

Specifications

Model	BM-916A · BM-917A									
Subclass	1	2	3	4	5	6	*7	*8	For shank button	
Sewing pattern										
Max. sewing speed	1,500 rpm									
No. of stitches	8, 16, 32	6, 12, 24	8, 16, 32	6, 12, 24	8, 16, 32	6, 12, 24	8, 16, 32	6, 12, 24	8, 16, 32	
Needle	TQ × 1 #16								TQ × 7 #16	
Button size	10 – 20mm (Items 10 to 30 are sold separately)								A (φ5 - φ20) B (φ1.5 - φ5.5) C (φ3.2 - φ5) D (φ1.6 - φ3.2)	
Button hole spacing	2.0 – 6.5 × 0 – 6.5 mm (Width × Length)						2.0 – 6.5 × 0 mm			
Height of button clamp lift stroke	14 mm								20 – 25 mm	
Thread trimmer	BM-916A : No BM-917A : Yes									



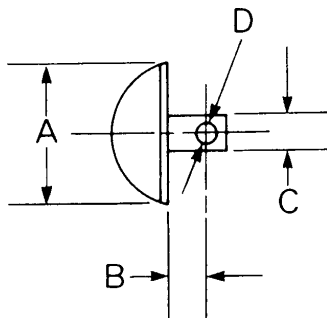

*Subclasses -7 and -8 are only for BM-917A.

*Shank button size:



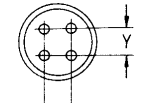

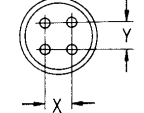









BM-916A-00□

BM-917A-00□

Stitch pattern, feed length (X – Y)								
-1		Button sewing in invert "C" shape	 2.0 - 6.5 × 0 - 6.5 (mm)	-5		Button sewing "X" shape	 2.0 - 6.5 × 0 - 6.5 (mm)	
-2				-6				
-3		Button sewing "Z" shape			-7		Temporary label attaching stitch (only for BM-917A) *Stitch gets loose as pulling thread end	2.0 - 6.5 × 0 (mm)
-4					-8			

*Subclasses -7 and -8 are only for BM-917A.

Optional attachments

Attachment Sewing pattern	Label flat button set (size 10-30 mm) (S03633-001)	Root wound button (floated sewing) Root wound button (wound sewing) (150416-001)	Shank attachment (including metal button clamp) (142570-109)	Snap clamp set (S03635-101)	Label attachment (S03692-001)	Stay button attachment S (S03693-001)	Mechanical 2-pedal set (S03655-002)
	○	○	○	○	○	○	○
	○	○	○	-	○	○	○
	○	○	○	-	○	○	○
	○	-	-	-	○	-	○
	 Flat button	 Floating sewing  Root wound button	 Metal button  Shank button	 Snap	 Label	 Stay button	

Button clamp set

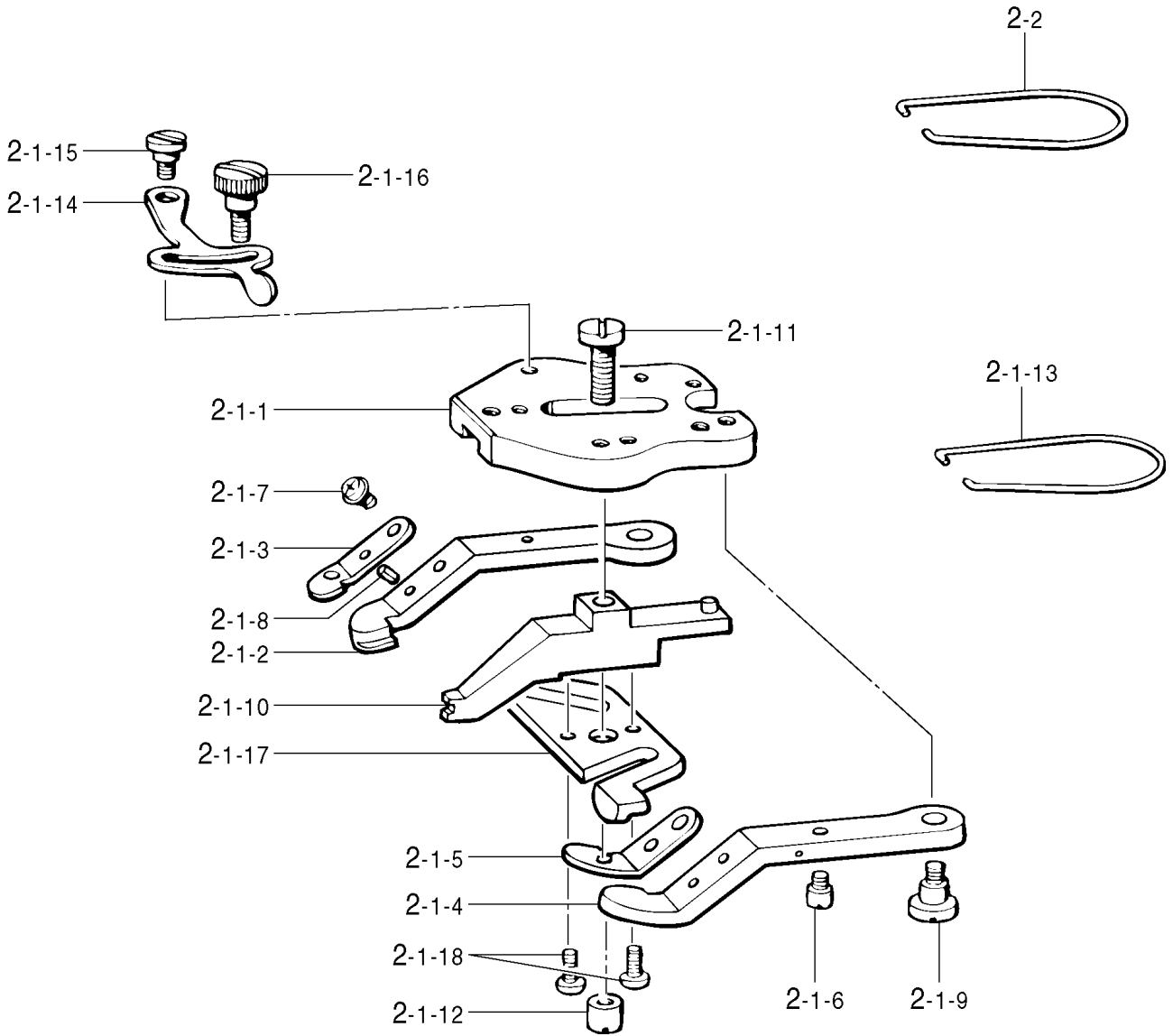

Button clamp set

Ref. No.	Part name	Part code	Q'ty
<For button size $\phi 10 - \phi 20$ >			
2	Button clamp set (A)	S03701-001	1
2-1	Button clamp assy	S30015-101	1
2-1-1	Button clamp bracket	S03464-101	1
2-1-2	Button clamp (L)	S29998-001	1
2-1-3	Spring, plate	S30001-001	1
2-1-4	Button clamp (R)	S29999-001	1
2-1-5	Spring, plate	S30002-001	1
2-1-6	Pin	115156-001	2
2-1-7	Screw, pan M4.37 - 40 x 5	062680-512	2
2-1-8	Pin, spring roll AW2.5	047250-642	2
2-1-9	Shoulder screw, M4.76	115158-001	2
2-1-10	Button clamp (M) assy	S29954-001	1
2-1-11	Screw, M4.37	S03468-101	1
2-1-12	Nut, M4.37	S03657-001	1
2-1-13	Spring, plate	115163-001	1
2-1-14	Button clamp adjust plate	115164-101	1
2-1-15	Shoulder screw, M4.37	115165-001	1
2-1-16	Shoulder screw, M4.37	115166-001	1
2-1-17	Button clamp plate cam	S03659-001	1
2-1-18	Screw, pan M4.37 - 40 x 8	062680-812	2
2-2	Spring	S03610-001	1
<For button size $\phi 10 - \phi 30$ >			
2	Button clamp set (B)	S03633-001	1
2-1	Button clamp assy (B)	S03634-101	1
2-1-1	Button clamp bracket	S03464-101	1
2-1-2	Button clamp (LB)	S03650-001	1
2-1-3	Spring, plate	S11079-001	1
2-1-4	Button clamp (RB)	S03649-001	1
2-1-5	Spring, plate	S11080-001	1
2-1-6	Pin	115156-001	2
2-1-7	Screw, pan M4.37 - 40 x 5	062680-512	2
2-1-8	Pin, spring roll AW2.5	047250-642	2
2-1-9	Shoulder screw, M4.76	115158-001	2
2-1-10	Button clamp (M) assy	S03467-001	1
2-1-11	Screw, M4.37	S03468-101	1
2-1-12	Nut, M4.37	S03657-001	1
2-1-13	Spring, plate	115163-001	1
2-1-14	Button clamp adjust plate	115164-101	1
2-1-15	Shoulder screw, M4.37	115165-001	1
2-1-16	Shoulder screw, M4.37	115166-001	1
2-1-17	Button clamp plate cam	S03659-001	1
2-1-18	Screw, pan M4.37 - 40 x 8	062680-812	2
2-2	Spring	S03610-001	1

Optional attachment for shank button

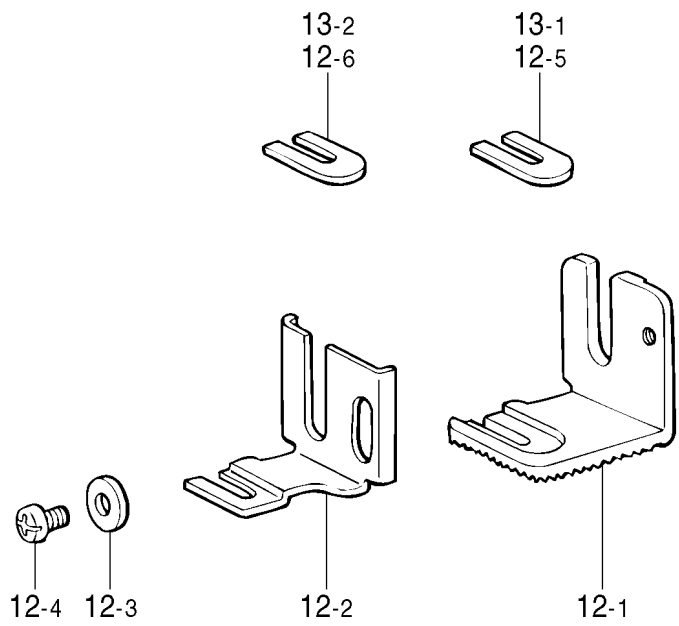
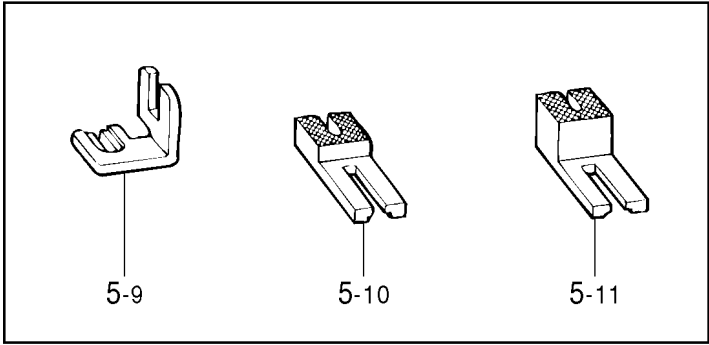
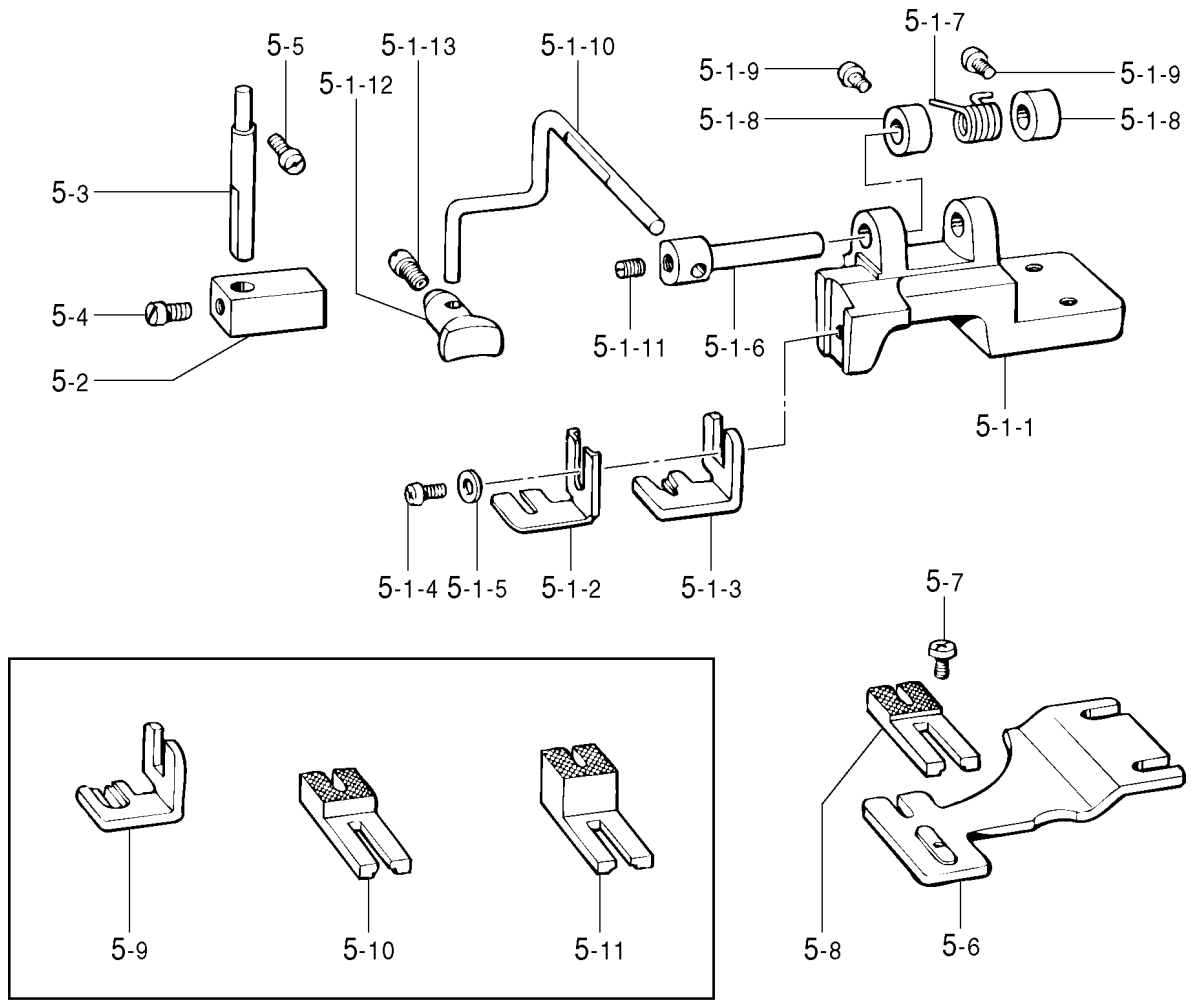

From the library of: Diamond Needle Corp

Optional attachment for shank button

Ref. No.	Part name	Part code	Q'ty
5	Shank button attachment	142570-109	1
5-1	Shank button clamp assy	142689-309	1
5-1-1	Shank button clamp bracket	154684-009	1
5-1-2	Button clamp (A)	142677-101	1
5-1-3	Button clamp (B)	142678-101	1
5-1-4	Screw, pan M3.57 – 40 × 8	062670-812	1
5-1-5	Washer	102707-003	1
5-1-6	Button presser stud	142681-001	1
5-1-7	Spring	154685-001	1
5-1-8	Set screw collar	142706-001	2
5-1-9	Screw, pan M3.57 – 40 × 7	062670-712	2
5-1-10	Button presser arm	154686-001	1
5-1-11	Set screw, (CP) M4.76	013719-412	1
5-1-12	Button presser	142680-001	1
5-1-13	Set screw, M4.37	120990-001	1
5-2	Button presser arm lifter	142683-101	1
5-3	Button presser arm lifter bar	142684-001	1
5-4	Set screw, M4.37	120990-001	1
5-5	Screw, pan M4.76 – 32 × 10	062711-012	1
5-6	Shank button feed plate	156336-101	1
5-7	Screw, bind M3.57 – 40 × 5	060670-512	1
5-8	Cloth receiver (S)	142686-101	1
5-9	Button clamp (D)	S03641-101	1
5-10	Cloth receiver (middle)	142687-101	1
5-11	Cloth receiver (large)	142688-001	1
12	Shank gauge kit	S10654-001	1
12-1	Button clamp (E)	S10560-001	1
12-2	Button clamp (F)	S10651-001	1
12-3	Washer	105161-003	1
12-4	Screw, pan M3.57 – 40 × 3.5	S39086-001	1
12-5	Button guide (1.5)	S10652-000	5
12-6	Button guide (1.0)	S10653-000	5
13	Button guide set	S10655-001	1
13-1	Button guide (1.5)	S10652-000	10
13-2	Button guide (1.0)	S10653-000	10

Optional attachment for shank button

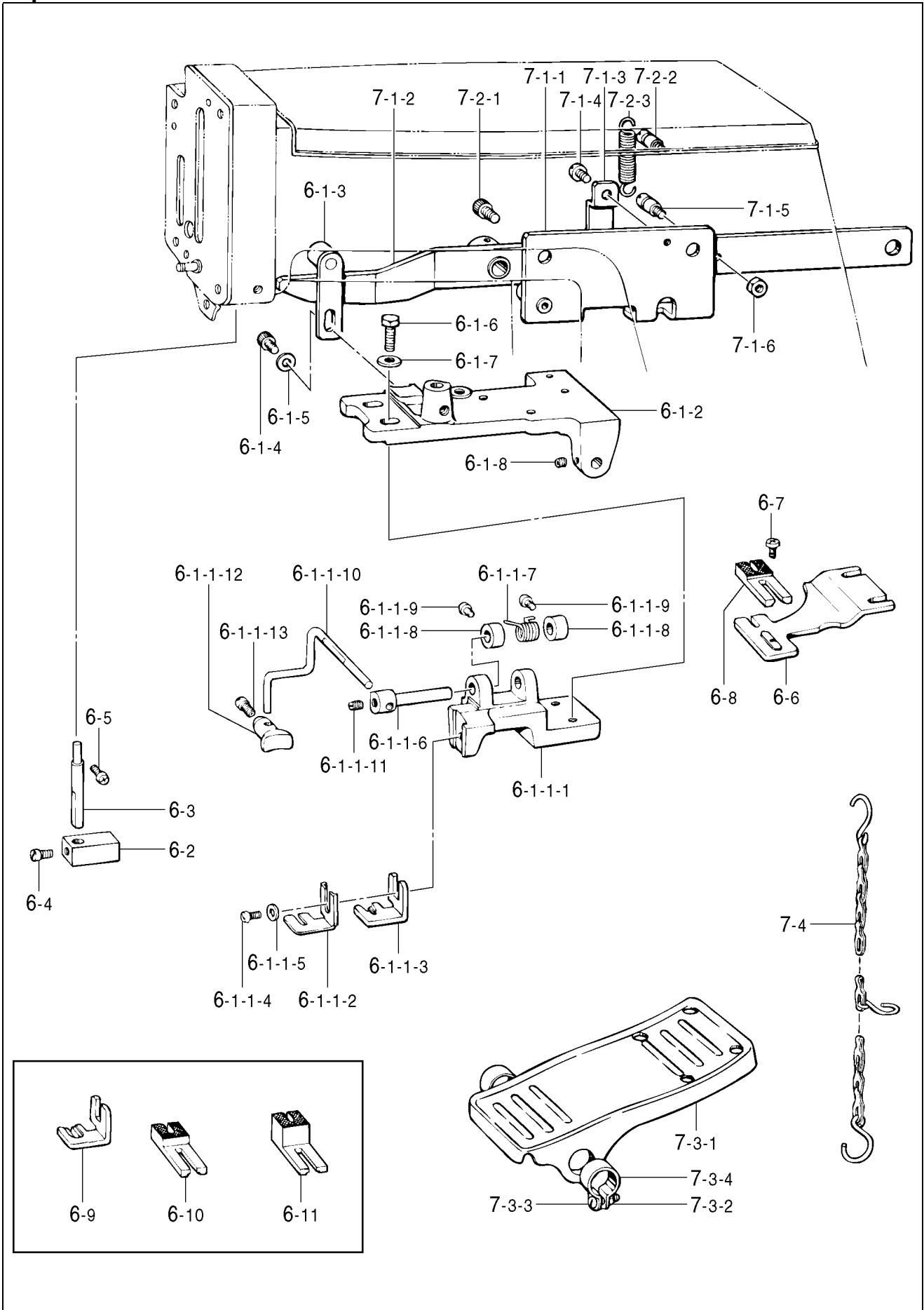

Optional attachment for shank button

Ref. No.	Part name	Part code	Q'ty
6	Shank device set	S39822-109	1
6-1	Shank button clamp assy	S39823-109	1
6-1-1	Shank button clamp assy	142689-309	1
6-1-1-1	Shank button clamp bracket	154684-009	1
6-1-1-2	Button clamp (A)	142677-101	1
6-1-1-3	Button clamp (B)	142678-101	1
6-1-1-4	Screw, pan M3.57 - 40 x 8	062670-812	1
6-1-1-5	Washer	102707-003	1
6-1-1-6	Button presser stud	142681-001	1
6-1-1-7	Spring	154685-001	1
6-1-1-8	Set screw collar	142706-001	2
6-1-1-9	Screw, pan M3.57 - 40 x 7	062670-712	2
6-1-1-10	Button presser arm	154686-001	1
6-1-1-11	Set screw, (CP) M4.76	013719-412	1
6-1-1-12	Button presser	142680-001	1
6-1-1-13	Set screw, M4.37	120990-001	1
6-1-2	Presser arm	S37352-009	1
6-1-3	Presser adjust plate assy	S03459-051	1
6-1-4	Bolt, socket M6 x 10	018061-022	1
6-1-5	Washer 6	S03695-001	1
6-1-6	Bolt, M4.76 x 14	017711-412	2
6-1-7	Washer	146354-001	2
6-1-8	Set screw, socket (CP) M4.37	014680-622	2
6-2	Button presser arm lifter	142683-101	1
6-3	Button presser arm lifter bar	142684-001	1
6-4	Set screw, M4.37	120990-001	1
6-5	Screw, pan M4.76 - 32 x 10	062711-012	1
6-6	Shank button feed plate	156336-101	1
6-7	Screw, bind M3.57 - 40 x 5	060670-512	1
6-8	Cloth receiver (S)	142686-101	1
6-9	Button clamp (D)	S03641-101	1
6-10	Cloth receiver (middle)	142687-101	1
6-11	Cloth receiver (large)	142688-001	1
7	Mechanical two-pedal set	S03655-002	1
7-1	Presser lifter lever assy	S03714-001	1
7-1-1	Base plate	S03705-001	1
7-1-2	Presser lifter lever	S03706-001	1
7-1-3	Guide plate	S03707-001	1
7-1-4	Screw, pan M4.76 - 32 x 6	062710-612	1
7-1-5	Spring hook	S03625-001	1
7-1-6	Nut, M4.76	110161-004	1
7-2	Presser lifter spring assy	S37805-001	1
7-2-1	Bolt, socket M6 x 14	018061-422	2
7-2-2	Spring hook	S03625-001	1
7-2-3	Spring	S03624-001	1
7-3	Pedal assy	116185-209	1
7-3-1	Foot lifter pedal	117437-109	1
7-3-2	Nut, 1M4	021400-106	2
7-3-3	Screw, pan M4 x 14	062401-416	2
7-3-4	Pedal stopper	116016-001	2
7-4	Chain assy	142656-001	1

Optional attachment

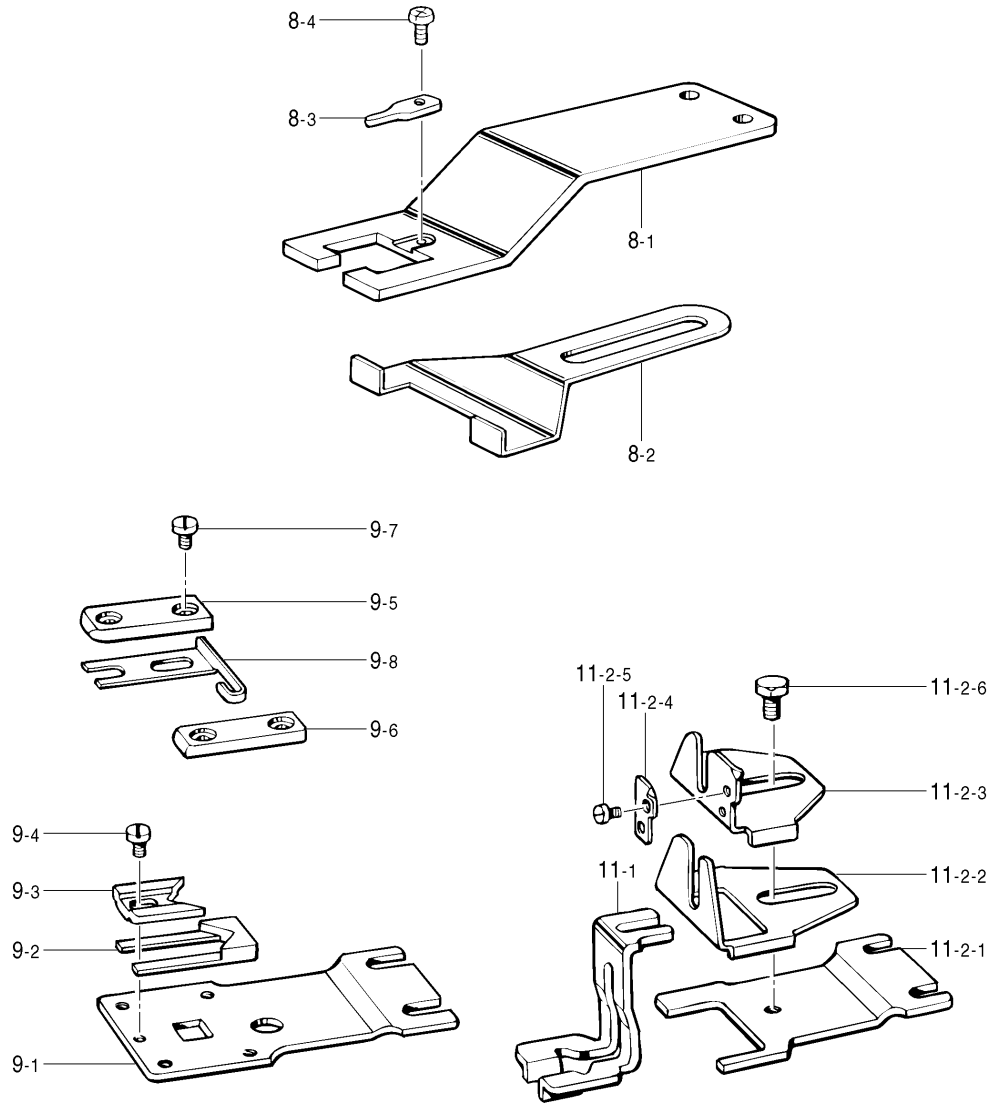

Ref. No.	Part name	Part code	Q'ty
8	Label attachment	S03692-001	1
8-1	Label clamp	S09144-001	1
8-2	Stopper	S09143-001	1
8-3	Clamp spring	S09145-001	1
8-4	Screw, M2.38 × 3.5	S01295-001	2
9	Stay button attachment (S)	S03693-001	1
9-1	Stay button feed plate	S09482-001	1
9-2	Button receiver (D)	S09483-001	1
9-3	Button receiver (U)	S09484-001	1
9-4	Screw, M3.18 – 44 × 3.4	S09494-001	1
9-5	Receiver guide (L)	S09485-001	1
9-6	Receiver guide (R)	S09486-001	1
9-7	Screw, M3.18 – 44 × 4	S09493-001	4
9-8	Receiver support spring	S09487-001	1
11	Button root wrapping attachment	150416-001	1
11-1	Lifting gauge	S09488-001	1
11-2	Wrapping gauge assy	S09564-001	1
11-2-1	Root wrapping button feed plate	S09489-001	1
11-2-2	Button root wrapping receiver (A)	S09490-001	1
11-2-3	Button root wrapping receiver (B)	S09491-001	1
11-2-4	Thread clamp	S09492-001	1
11-2-5	Screw, M2.38 – 56 × 1.9	S09496-001	2
11-2-6	Bolt, M4.37 – 40 × 4.5	S09495-001	1

Optional attachment

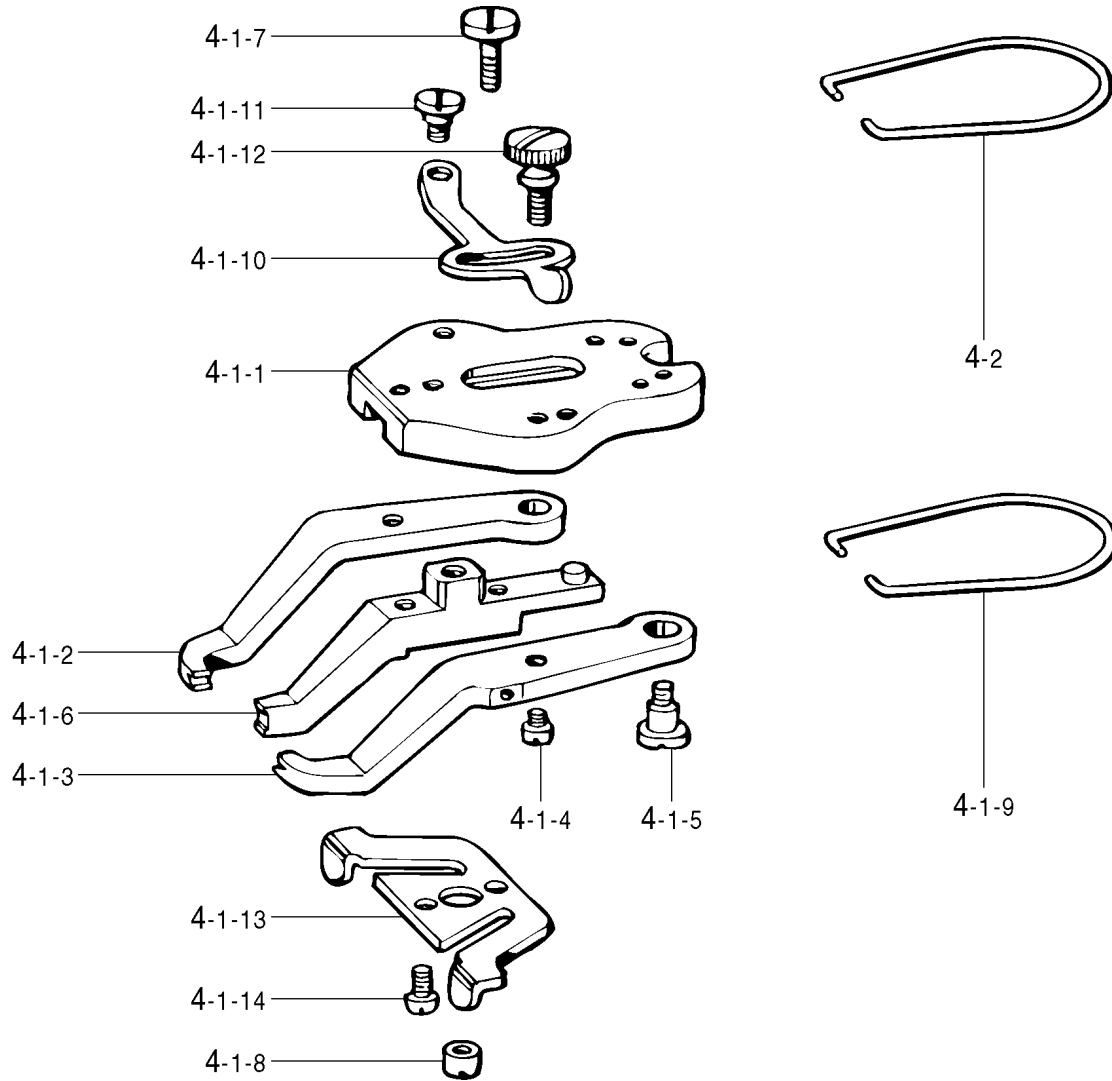

Ref. No.	Part name	Part code	Q'ty
4	Snap clamp set	S03635-101	1
4-1	Snap clamp assy	S03636-101	1
4-1-1	Button clamp bracket	S03464-101	1
4-1-2	Snap clamp (L)	118541-001	1
4-1-3	Snap clamp (R)	118539-001	1
4-1-4	Pin	115156-001	2
4-1-5	Shoulder screw, M4.76	115158-001	2
4-1-6	Snap clamp (M) assy	S03712-001	1
4-1-7	Screw, M4.37	S03468-101	1
4-1-8	Nut, M4.37	S03657-001	1
4-1-9	Spring, plate	115163-001	1
4-1-10	Button clamp adjust plate	115164-101	1
4-1-11	Shoulder screw, M4.37	115165-001	1
4-1-12	Shoulder screw, M4.37	115166-001	1
4-1-13	Button clamp plate cam	S03659-001	1
4-1-14	Screw, pan 4.37 - 40 x 8	062680-812	2
4-2	Spring	S03610-001	1

Option parts

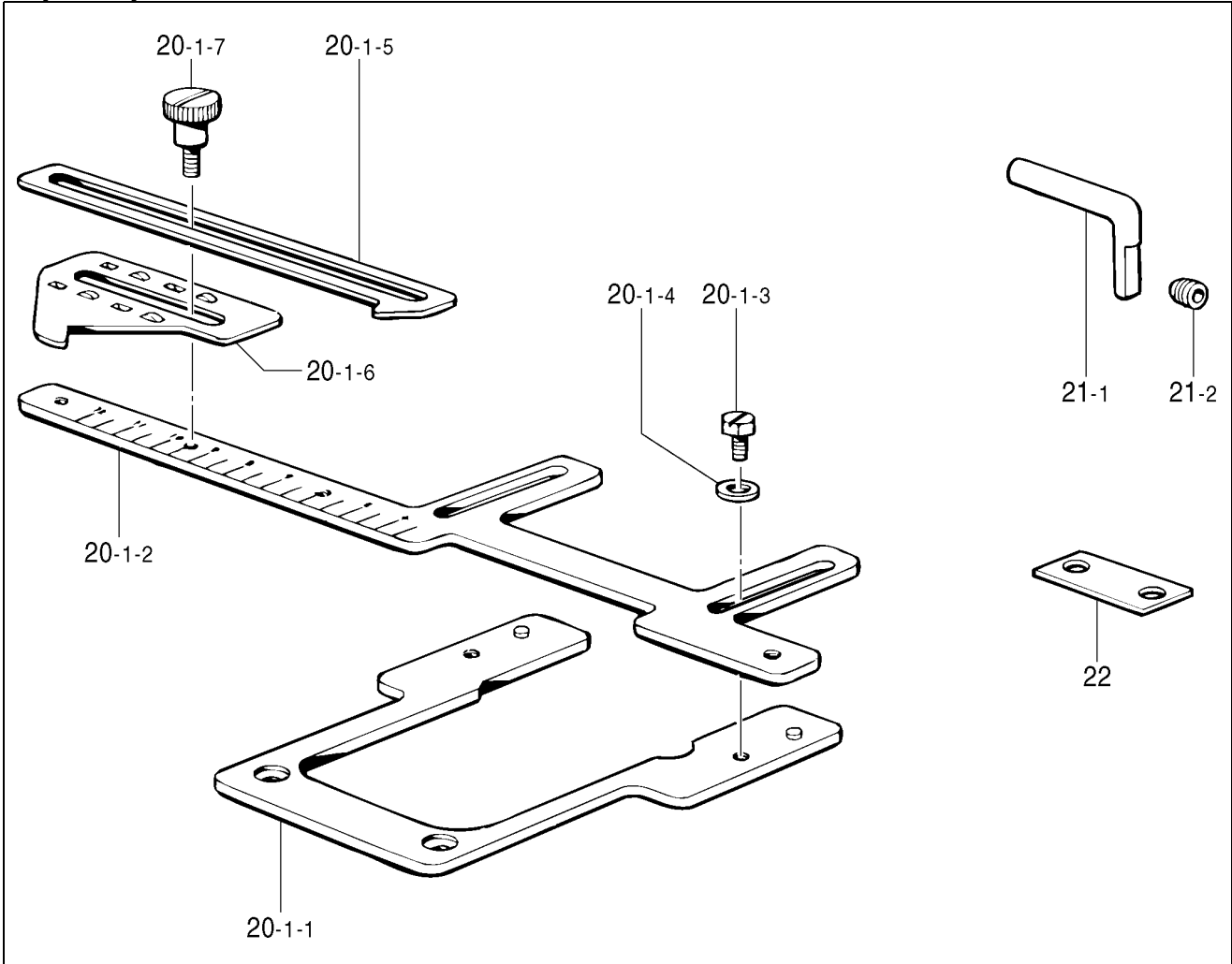





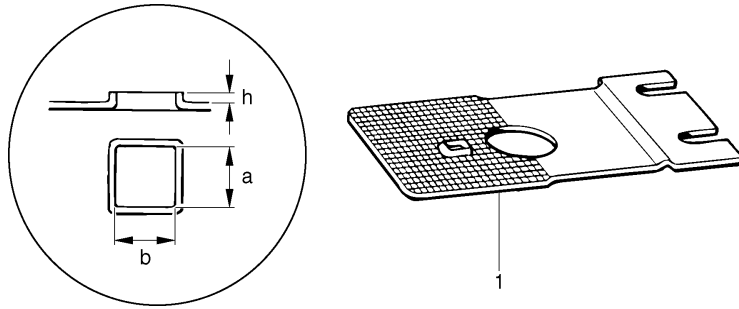



Ref. No.	Part name	Part code	Q'ty
20	Button spacer set	S09655-001	1
20-1	Button spacer assy	S09656-001	1
20-1-1	Base	S09657-001	1
20-1-2	Scale	S09658-001	1
20-1-3	Bolt, M4.37 - 40 × 7	S09686-001	2
20-1-4	Washer	S02745-001	2
20-1-5	Positioning set plate (A)	S09659-001	1
20-1-6	Positioning set plate (B)	S09660-001	1
20-1-7	Shoulder screw, M4.37	115166-001	1
21	Button holder hook assy	S38181-001	1
21-1	Button holder hook	S36813-001	1
21-2	Set screw, socket (CP) M5.95	014760-622	1
22	Feed spacer	S37370-001	1

Option parts



Ref. No.	Part name	Part code	a × b × h	Remarks
1	Feed plate (A)	S03476-101	4.8 × 4.8 × 0.8	Standard
1	Feed plate (B)	S03630-101	4.8 × 4.8 × 0	For  shape button
1	Feed plate (C)	115085-001	7 × 7 × 0	For L pitch
1	Feed plate (D)	S03632-101	7 × 7 × 0.8	For L pitch
1	Feed plate (E)	S16121-101	8 × 2 × 0	For label attachment

Different parts list

Subclass	Stitch form	No. of stitches	Part name				
			Stitch control cam assy	Worm gear assy	Transverse feed cam assy	Vertical feed cam assy	Worm assy
BM-916A BM-917A -1		8 · 16 · 32	S36696-001	S03445-001	S03446-001	S03451-001	S03528-001
BM-916A BM-917A -3			S36696-001	S03445-001	S03447-001	S03451-001	S03528-001
BM-916A BM-917A -5			S36696-001	S03445-001	S03446-001	S03452-001	S03528-001
BM-917A -7	 (Temporary label attaching stitch)		S36696-001	S03445-001	S03446-001	S03596-001	S03528-001
BM-916A BM-917A -2		6 · 12 · 24	S36697-001	S03651-001	S03448-001	S03451-001	S03653-001
BM-916A BM-917A -4			S36697-001	S03651-001	S03449-001	S03451-001	S03653-001
BM-916A BM-917A -6			S36697-001	S03651-001	S03448-001	S03454-001	S03653-001
BM-917A -8	 (Temporary label attaching stitch)		S36697-001	S03651-001	S03448-001	S03597-001	S03653-001